

# Full Color Chip LED

## ALC-F553

RoHS Compliant



### Characteristics

- 1) Three die equals full color capabilities
- 2) Uniformed spatial radiation pattern
- 3) Compact package
- 4) High reliability

#### Absolute Maximum Ratings at Ta=25°C

Item	Symbol	Value			Unit
		Red	Green	Blue	
Power Dissipation *1	P <sub>D</sub>	400			mW
Forward Current	I <sub>F</sub>	50			mA
Pulse Forward Current *2	I <sub>FP</sub>	120	100		mA
Reverse Voltage	V <sub>R</sub>	5.0			V
Operating Temperature Range	T <sub>opr</sub>	-20 to +85			°C
Storage Temperature Range	T <sub>stg</sub>	-30 to +100			°C
Soldering Temperature Range	T <sub>sol</sub>	Reflow soldering: 260°C max., 5 seconds max. Soldering iron: 300°C max., 3 seconds max.			°C

\*1 Value when two or more devices are lit simultaneously.

\*2 Duty 1/10, Pulse width 1ms

#### Optical Characteristics at Ta=25°C

Item	Symbol		Value			Unit	Condition
			Red	Green	Blue		
Forward Voltage	V <sub>F</sub>	Typ	2.1	3.3	3.2	V	I <sub>F</sub> =20mA
		Max	2.6	3.8	3.8		
Reverse Current	I <sub>R</sub>	Typ	-	-	-	μA	V <sub>R</sub> =5V
		Max	100	100	100		
Luminous Intensity	I <sub>v</sub>	Typ	650	1600	480	mcd	I <sub>F</sub> =20mA
		Max	-	-	-		
Dominant Wavelength	λ <sub>d</sub>	Typ	616	522	467	nm	I <sub>F</sub> =20mA
		Max	-	-	-		
Spectral line half-width	Δλ	Typ	20	33	23	nm	I <sub>F</sub> =20mA
		Max	-	-	-		

## Package Dimensions

Unit : mm  
Tolerance :  $\pm 0.1$

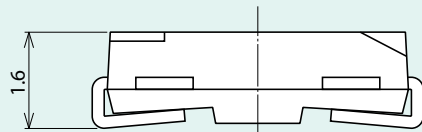
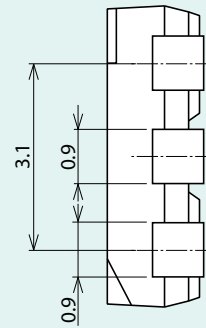
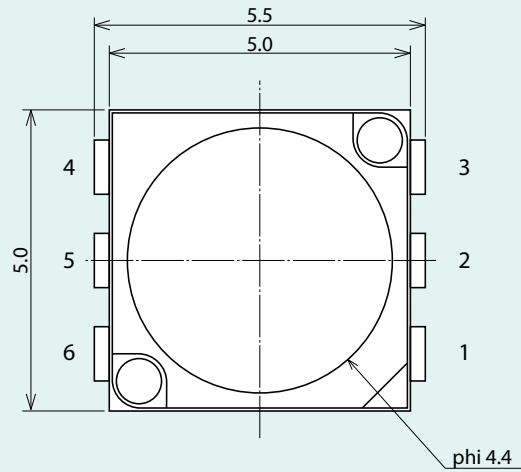

Do not put on the stress to the top.

[Circuit diagram]

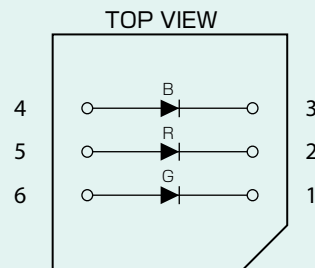

**A'SYCK Co., Ltd.**

37-1, Nishiura, Hironocho, Uji City, Kyoto, JAPAN 611-0031  
Phone: 010-81-774-41-3777 Fax: 010-81-774-44-6575